

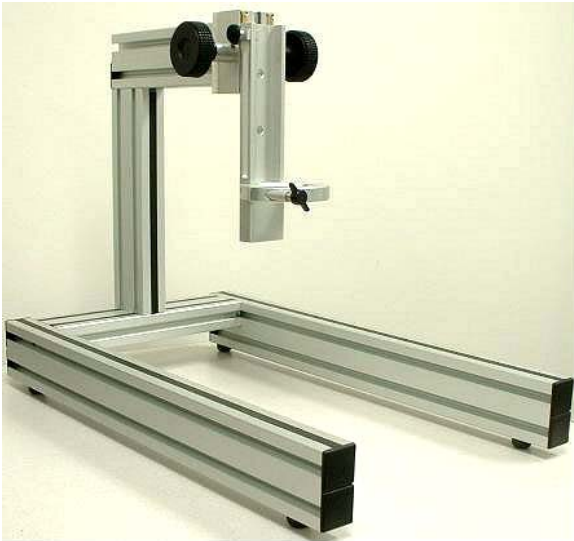

Operation and Maintenance Manual for the ST 500 Series Accessories

P/N 5050-0542



ST 500 Handpiece Fixture

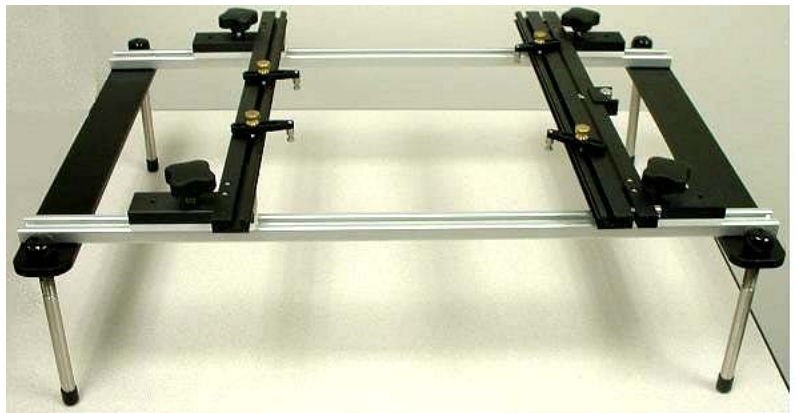

ST 525/550 PCB Holder

TITLE	PAGE
General Information	3
Introduction.....	3
Specifications	3
Parts Identification.....	4
Safety Guidelines	5
ST 500 Set-Up	6
Handpiece Mounting	6
ST 500 Operation	6
ST 525/ST 550 Set-Up.....	7
Leg Installation and Adjustment	7
ST 525/ST 550 Operation	8
Board Installation (for standard boards).....	8
Board Installation (for odd shape boards).....	9
ST 500 Packing List	10
ST 525/ST 550 Packing List	10
Service	10
“SODRTEK by PACE” LIMITED WARRANTY STATEMENT	11
Contact Information.....	12

General Information

Introduction

Thank you for purchasing the SODRTEK®'s ST 500 Series Fixtures. This manual will provide you with the information necessary to properly set up, operate, and maintain the fixtures. The ST 500 is a Z-axis fixture that provides a precision vertical slide that converts the ST 300 and ST 325 hot air handpiece into a fixed reflow head. The ST 525 and ST 500 accessories will support a variety of PCB assemblies. The ST 525 will accept a PCB up to 12" x 12". The ST 550 handles larger PCB assemblies up to 18" x 18". The PACE ST 400 and ST 450 pre-heaters can be utilized with any of the ST 500 Series Fixtures.

Specifications

ST 500

Physical Parameters

Size – 53.34 cm H x 30.48 cm W x 49.53 cm D (21" H x 12" W x 19.5" D)

Unit Weight – 3.63 Kg. (8 lbs.)

ST 525

Board Capacity - (maximum size) – 30.48 cm x 30.48 cm (12" x 12") *Nominal*
(minimum size) – 0 cm, board holder closes completely

Physical Parameters (maximum dimensions with legs installed)

Size – 17.39 cm H x 49.53 cm W x 35.56 cm D (6.85" H x 19.50" W x 14.0" D)

Unit Weight – 1.99 Kg. (4.38 lbs.)

ST 550

Board Capacity - (maximum size) – 45.72 cm x 45.72 cm (18" x 18") *Nominal*
(minimum size) – 0 cm, board holder closes completely

Physical Parameters (maximum dimensions with legs installed)

Size – 17.39 cm H x 64.77 cm W x 35.56 cm D (6.85" H x 25.50" W x 14.0" D)

Unit Weight - 4.5 Kg. (9.8 lbs.)

Parts Identification

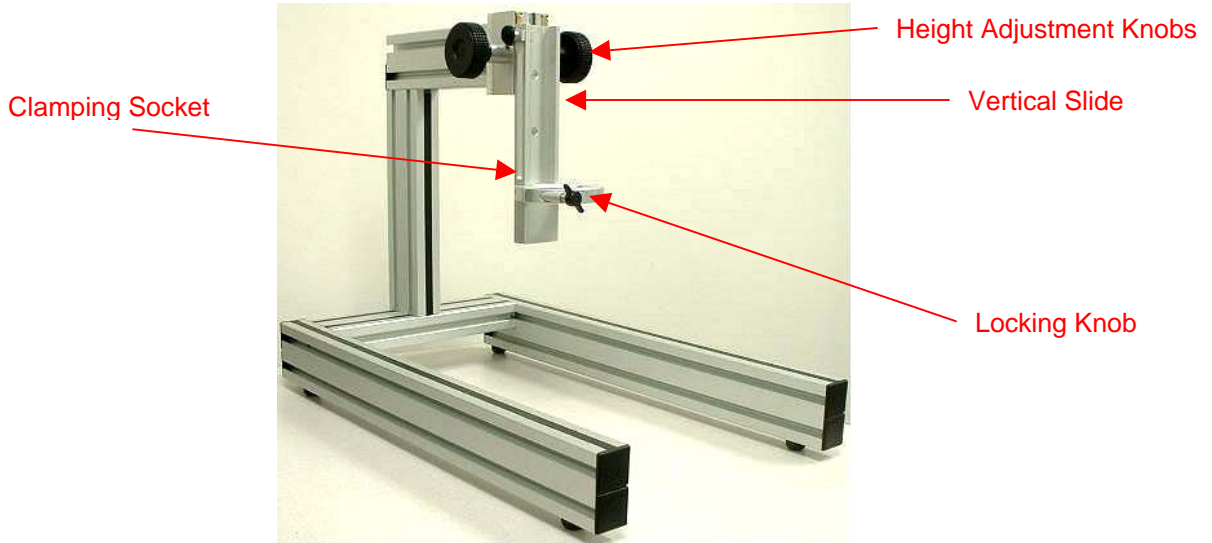
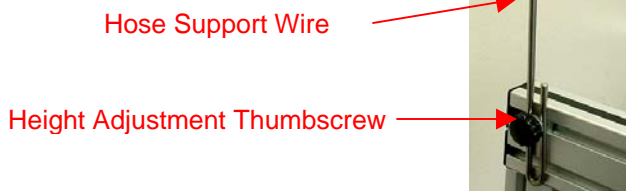

ST 500 Handpiece Fixture

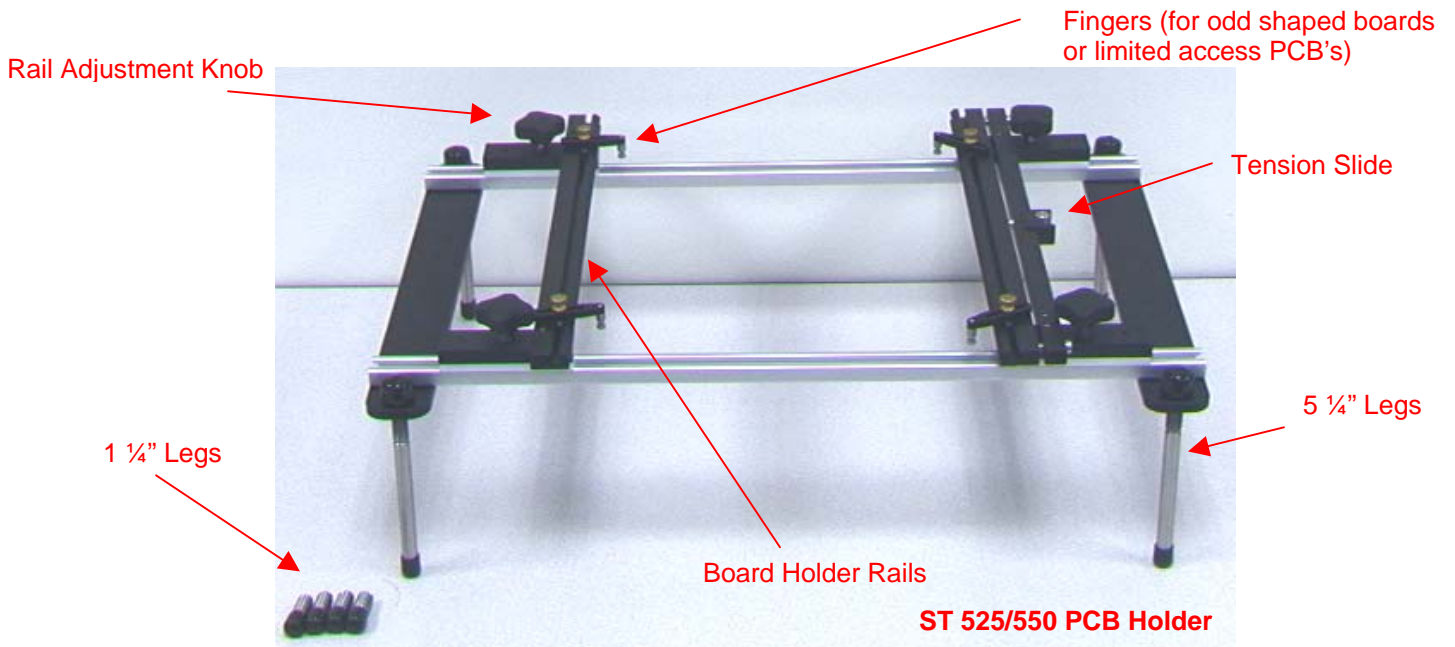

ST 525/550 PCB Holder

Safety Guidelines

The following are safety precautions that personnel must understand and follow when using or servicing this product.

1. To prevent personnel injury, adhere to safety guidelines in accordance with OSHA and other applicable safety standards.
2. Always use PACE systems in a well ventilated area. A fume extraction system such as those available from PACE are highly recommended to help protect personnel from solder flux fumes.
3. Exercise proper precautions when using chemicals (e.g., solder paste). Refer to the Material Safety Data Sheet (MSDS) supplied with each chemical and adhere to all safety precautions recommended by the manufacturer.

ST 500 Set-Up

Set up the ST 500 fixture using the following steps and associated drawings.

Handpiece Mounting

The following steps will demonstrate how to attach the ST 300 or the ST 325 handpiece to the ST 500.

1. Unscrew the Plastic Heat Shield (marked "HOT") from the handpiece and set aside.
2. Install the metal Swivel Ring (part number 1321-0320) onto the handpiece.
3. Turn the Locking Knob counterclockwise several turns to release the Clamping Socket.
4. Pull the Locking Knob forward. The Clamping Socket will swing open at the knob.
5. Place the handpiece, positioned at an angle with the heater down, through the center of the Clamping Socket.
6. The Clamping Socket and the Swivel Ring (on handpiece) form a ball and socket attachment mechanism. Slide the Swivel Ring into the Clamping Socket.
7. Straighten the handpiece up into a vertical position. Ensure that the Swivel Ring remains inside the Clamping Socket.
8. Push the Locking Knob and turn clockwise to secure the handpiece in position.

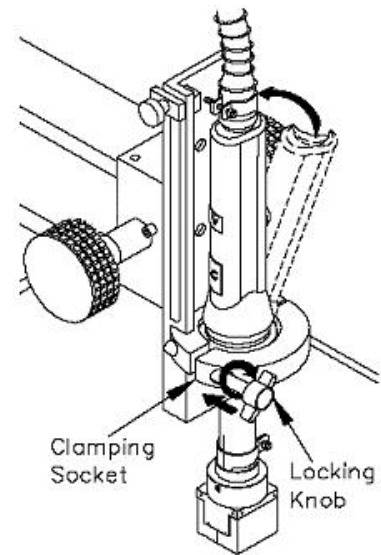
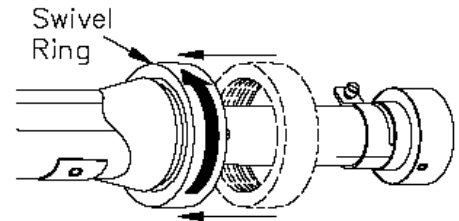

ST 500 Operation

The ThermoFlo handpiece can be easily raised or lowered using either of the Height Adjustment Knobs. To provide repeatable clearance of an attached nozzle assembly relative to the surface of PCB assembly (Nozzle-to-PCB clearance), do the following:

1. Loosen the Locking Knob. The Clearance Limiter Assembly will now fall down against the Stop.
2. Lower the handpiece to the desired distance of Nozzle-to-PCB clearance using the Height Adjustment Knobs.
3. Ensure contact between the Clearance Limiter Assembly and the Stop. Tighten the Clearance Limiter Locking Knob to secure the Clearance Limiter Assembly in position on the Vertical Slide.

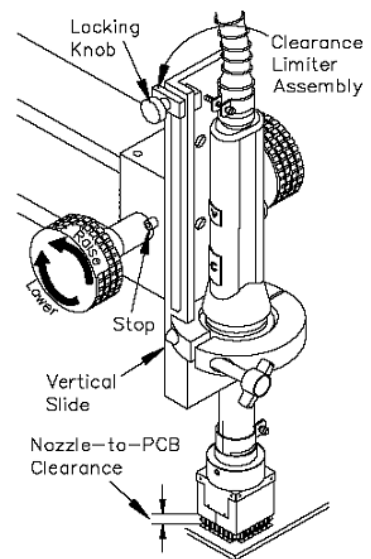

ST 525/ST 550 Set-up

Leg Installation and Adjustment

The ST 525/550 comes with two different sets of legs. The longer, 5 ¼" legs are to be used with the ST 400/425 Pre-Heating Systems. The 1 ¼" legs are suggested when a pre-heater system is not being used.

ST 525 shown
with the ST 450
Pre-Heater

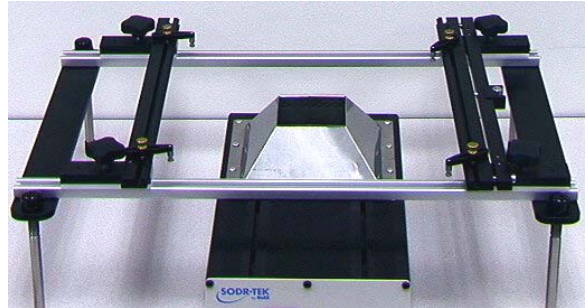

1. Select the desired legs.

NOTE: Use the long legs in front and the short legs in back to angle PCB for easy access.

2. Thread the desired legs into the base of the ST 525/550.
3. Thread the jam nut onto the top of the threaded portion of the leg.

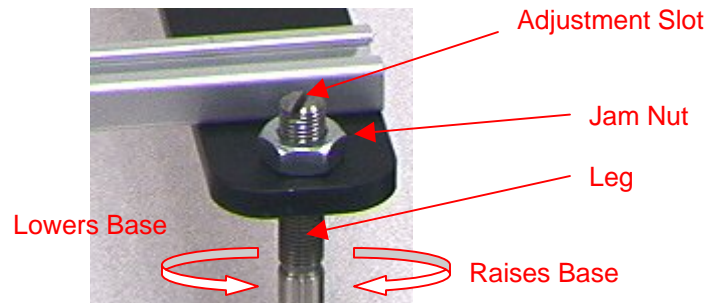

4. Adjust the legs to the desired height by turning them counter clockwise to lower the base and by turning the legs clockwise to raise the base.
5. Once the base is at the desired height tighten the jam nut while holding the leg. A flat blade screwdriver can be inserted into the slot on the top of the leg to prevent it from turning.
6. Once completed, the Protective Black Caps may be installed on the top of the jam nuts.

NOTE: If the leg is set for the lowest position, the black caps will not attach to the jam nut properly.

ST 525/ST 550 Operation

NOTE: The various boards can be installed using either the Fingers for odd shaped boards or by placing the board into the upper or lower channels in the Board Holder Rails.

Board Installation (For Standard Boards)

Example of typical usage for a standard board.

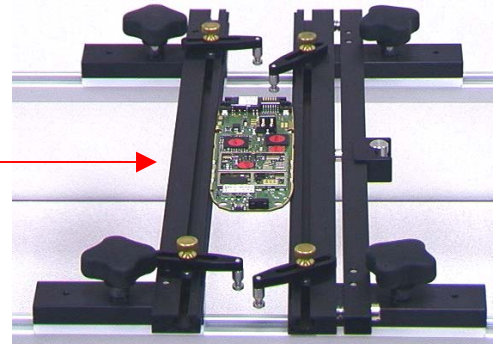

Tension Slide

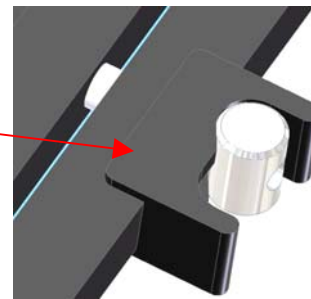

Tension "Off"

Tension "On"

1. Loosen the Rail Adjustment Knobs.
2. Verify that the tension is "off" on the Tension Slide. Note that when the tension is removed, the Board Holder Rail is retracted.

Tension Removed



NOTE: The tension slide is used to apply a small amount of tension on the PCB assembly once the Board Holder Rails are secured in place. This additional tension will help further retain the PCB in the fixture.

3. Position one of the Board Holder Rails into the desired position and then tighten the Rail Adjustment Knobs on that side only. **(DO NOT OVERTIGHTEN)**
4. Place the board on the Board Holder Rail that has already been secured, then slide the adjacent Rail Assembly to support the board.

Board Holder Rail

Rail Adjustment Knob

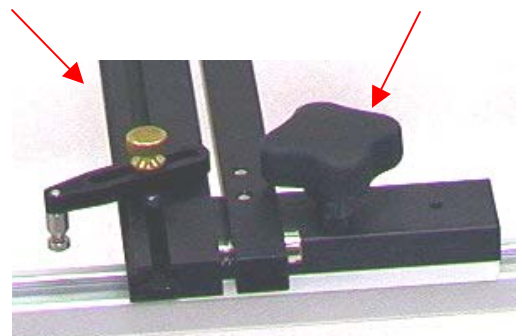

NOTE: There are two channels in the Board Holder Rail that will accept the board. This will allow the mounting of boards with various configurations.

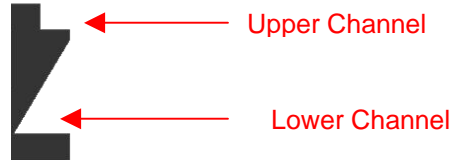

5. Tighten the Rail Adjustment Knobs. **(DO NOT OVERTIGHTEN)**

6. Place tension on the board by placing the Tension Slide into the proper position. At this point the Board Holder rail will extend and provide additional pressure on the PCB.

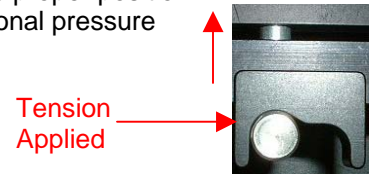

Board Installation (For Odd Shape Boards)

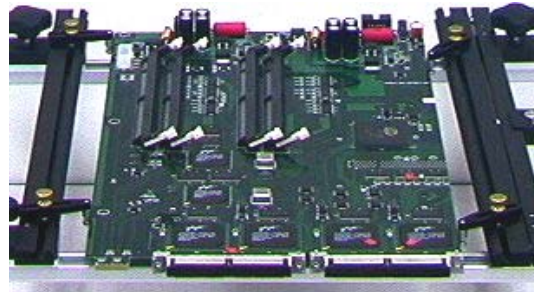

1. Loosen the Rail Adjustment Knobs.
2. Verify that the tension is "Off" on the Tension Slide.
3. Position one of the Board Holder Rails into the desired position and then tighten the Rail Adjustment Knobs on that side only. **(DO NOT OVERTIGHTEN)**
4. Slide the adjacent Rail Assembly at an approximate location where the board will rest.

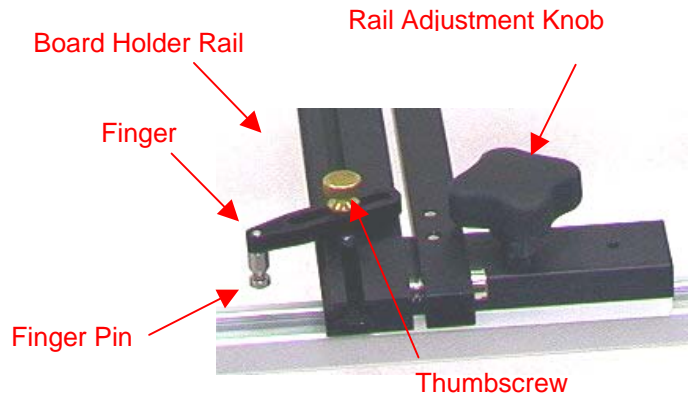

5. Loosen the Thumbscrew on the Finger.
6. Adjust the Finger into a position so that the board rests into the groove on the Finger Pin.
7. Tighten the Thumbscrew on the Finger.
8. Place tension on the board by placing the Tension Slide into the proper position.

ST 500 Packing List

Item #	Description	Part Number	Quantity
1	ST 500 Handpiece Fixture	6018-0129-P1	1
2	Hose Support Wire	1321-0797	1
3	Swivel Ring	1321-0320	1
4	Operations Manual CD	CD5050-0459	1

ST 525/ST 550 Packing List

Item #	Description	Quantity
1	ST 525 (6993-0253-P1) or ST 550 (6993-0254-P1)	1
2	1 ¼" Legs	4
3	5 ¼" Legs	4
4	Fingers (Odd shape boards)	4
5	Protective Caps (for top of legs)	4
6	Operations Manual CD (CD5050-0459)	1

Service

Please contact PACE or your local distributor for service and repair.

“SODRTEK by PACE” LIMITED WARRANTY STATEMENT

Limited Warranty

Seller warrants to the first user that products manufactured by it and supplied hereunder are free of defects in materials and workmanship for a period of one (1) year from the date of receipt by such user. Monitors, computers and other brand equipment supplied but not manufactured by PACE are covered under their respective manufacturer's warranty in lieu of this Warranty.

This warranty does not cover wear and tear under normal use, repair or replacement required as a result of misuse, improper application, mishandling or improper storage. Consumable items such as tips, heaters, filters, etc. which wear out under normal use are excluded. Failure to perform recommended routine maintenance, alterations or repairs made other than in accordance with Seller's directions, or removal or alteration of identification markings in any way will void this warranty. This warranty is available only to the first user, but the exclusions and limitations herein apply to all persons and entities. SELLER MAKES NO OTHER WARRANTY, EXPRESS OR IMPLIED, AND MAKES NO WARRANTY OF MERCHANTABILITY OR FITNESS FOR A PARTICULAR PURPOSE.

Seller will, at its option, repair or replace any defective products at its facility or other location approved by it at no charge to user, or provide parts without charge for installation by the user in the field at user's expense and risk. User will be responsible for all costs of shipping equipment to Seller or other location for warranty service.

EXCEPT FOR THE REMEDY ABOVE DESCRIBED, UNLESS OTHERWISE REQUIRED BY APPLICABLE LAW, SELLER WILL HAVE NO OTHER OBLIGATION WITH REGARD TO ANY BREACH OF WARRANTY OR OTHER CLAIM WITH RESPECT TO THE PRODUCTS, OR LIABILITY FOR ANY DIRECT, INDIRECT, CONSEQUENTIAL, OR INCIDENTAL LOSS OR DAMAGE CAUSED BY OR OCCURRING IN CONNECTION WITH ANY OF THE PRODUCTS.

Warranty service may be obtained by contacting the appropriate PACE Company or local Authorized PACE distributor as set forth below to determine if return of any item is required, or if repairs can be made by the user in the field. Any warranty or other claim with respect to the products must be made with sufficient evidence of purchase and date of receipt, otherwise user's rights under this warranty shall be deemed waived.

For PACE USA Customers:

PACE, INCORPORATED
9030 Junction Drive
Annapolis Junction, Maryland 20701
Tel. 301-317-3588
FAX. 301-498-3252

For PACE EUROPE Customers:

PACE EUROPE LIMITED
Sherbourne House, Sherbourne Drive,
Tilbrook, Milton Keynes
MK7 8HX
United Kingdom
Tel. (44) 1908 277666
WARRANTY SERVICE FAX: (44) 1908 277 777

All other Customers:

Local Authorized PACE Distributor

PACE Incorporated retains the right to make changes to specifications contained herein at any time, without notice. Contact your local authorized PACE Distributor or PACE Incorporated to obtain the latest specifications.

The following are trademarks and/or service marks of PACE, Incorporated, MD, USA:

INSTACAL™, FUMEFLO™, HEATWISE™, PACEWORLDWIDE™, PERMAGROUND™, POWERPORT™, POWERMODULE™, TEMPWISE™, TIP-BRITE™, AUTO-OFF™, and TEKLINK™.

The following are registered trademarks and/or service marks of PACE Incorporated, Annapolis Junction Maryland U.S.A.

ARM-EVAC®, FLO-D-SODR®, MINIWAVE®, PACE®, SENSATEMP®, SNAP-VAC®, SODRTEK®, SODR-X-TRACTOR®, THERMOFLO®, THERMOJET®, THERMOTWEEZ®, VISIFILTER®, THERMO-DRIVE®, and TOOLNET®.

PACE products meet or exceed all applicable military and civilian EOS/ESD, temperature stability and other specifications including MIL STD 2000, ANSI/JSTD 001, IPC7711, and IPC A-610.



www.paceworldwide.com

PACE USA

9030 Junction Drive
Annapolis Junction, MD 20701
USA

Tel: (301) 490-9860

Fax: (301) 498-3252

PACE Europe

Sherbourne House
Sherbourne Drive
Tilbrook, Milton Keynes
MK7 8HX
United Kingdom

(44) 01908-277666

(44) 01908-277777